



33 43312A03

Single-phase overexcitation rectifier

This single-phase overexcitation rectifiers specified below are designed to increase the attractive force, to reduce the **attraction time** of actuating solenoids, to reduce the **coupling** and **disconnection times** of clutches and brakes and to reduce the **power consumption** of clutches, brakes and actuating solenoids.

In order to increase the **attractive force** of actuating solenoids, the coil is overexcited during the overexcitation time applying a full wave rectified voltage. Afterwards, the rectifier changes over to the selected holding voltage, that shouldn't be higher than the specified nominal voltage of the solenoid. To lower the power consumption the nominal voltage of the solenoid should be not lower than the overexcitation voltage to achieve the nominal attractive force. The holding voltage can be adjusted depending of the dimensioning of the solenoid to a lower value than nominal. Owing to this

power saving effect the switch off time will be reduced without the necessity of DC-side switching due to the lower magnetic energy. An integrated **protective circuit** allows DC side switching, thus reducing fall times, coupling times and disconnection times. The integrated compensation of input voltage changes provides a better stabilized output voltage. The rectifier is designed for **powerless** switching on and off. Due to their compact plastic housing, these rectifiers can be mounted on top hat rails in switch cabinets. Plug-in screw terminals ensure simple installation.

CE

These products meet the requirements of EMC Directive 89/336/EEC. Compliance with the following standards is confirmed:
 EN 55011 (VDE 0875, part 11, 1992)
 Group 1, class A, disturbance voltage
 Group 1, class B, disturbance radiation
 EN 61000-4-3 (1997) severity level 3
 EN 61000-4-4 (1996) severity level 3
 EN 61000-4-5 (1996) severity level 3

The products comply with the **Low Voltage Directive 73/23/EEC**.

Compliance with the following standards is confirmed:
 HD625.1 S1 (1996) EN60529 (1991)

The products are considered components in the sense of the **Machinery Directive 98/37/EEC** and are not to be used until the machine in which they are to be incorporated is declared to conform to the requirements of the EC Directives.

Technical data

Type 33 433..	12A03
Rectifier type	Full wave rectifier with synchronous switched
Input voltage	230 / 115 VAC ± 10%
Frequency	40 – 60 Hz
Output voltage	
Overexcitation	205 / 102 VDC
Holding voltage adjustable at 50 Hz	20 – 120 VDC at 230 VAC 10 – 60 VDC at 115 VAC
Maximum output current with overexcitation	18 ADC
holding current	9 ADC
Overexcitation time adjustable	0,2 – 4 s
Min. recovery time	100 ms
Required relay output for powerless switching	15 mA / 115/230 VAC potential separated
Fuse: Fine wire fuse 6.3 x 32 delayed	T10/250V
Connection	8-pole plug in screw terminals, 2,5 mm ² fine wire
Ambient temperature	0 – 70 °C
Protection as per EN 60529	See diagram 2 for derating IP 00

Block diagram

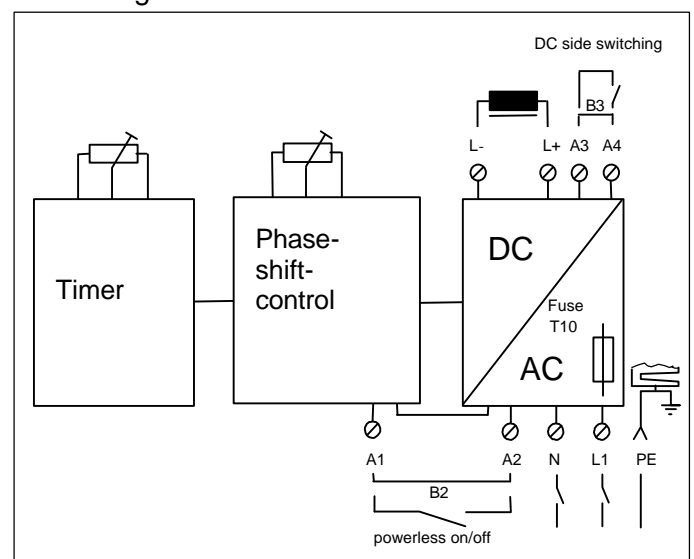

Specification subject to change without notice.
 Please observe ordering data!

Operating range

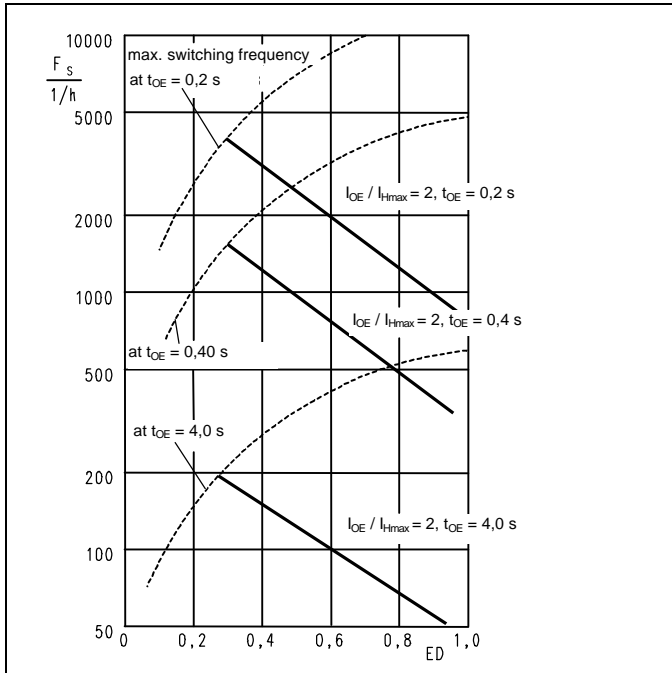

Diagram 1: Permissible maximum switch frequency
Rectifiers installed in switch cabinets with a minimum distance of 30 mm to adjacent units.

$$f_s = \frac{I_{Hmax}^2 - I_H^2 * ED}{(I_{oe}^2 - I_H^2) * t_{oe}}$$

f_s max. switch frequency
 I_{Hmax} max. holding current (See technical data)
 I_H adjusted holding current
 ED Duty cycle
 I_{oe} Overexcitation current
 t_{oe} Overexcitation time

Formula 1: Permissible maximum switch frequency

Permissible operating temperature

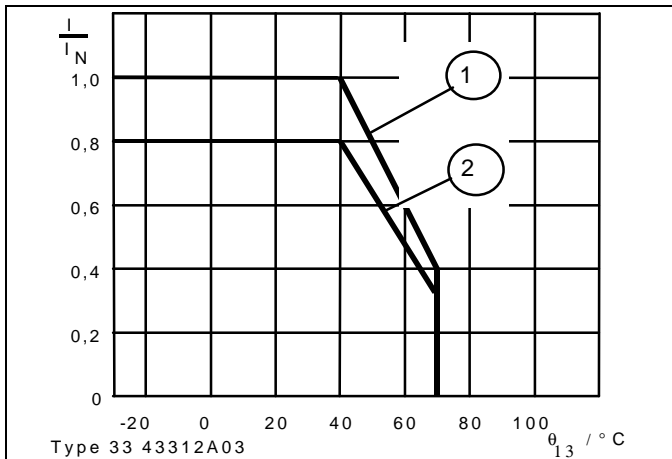

Diagram 2: Admissible current load at ambient temperature
 ① distance between 2 devices minimum 30 mm
 ② distance between 2 devices below 30 mm

**Kendrion Binder Magnete GmbH
Electronic Systems**

Plant:
Mönchweilerstraße 1
D-78048 Villingen-Schwenningen
Phone: +49 (0)7721 877-296

Mailing address:
Postfach 1220
D-78002 Villingen-Schwenningen
Fax: +49 (0)7721 877-293

Dimensions (mm)

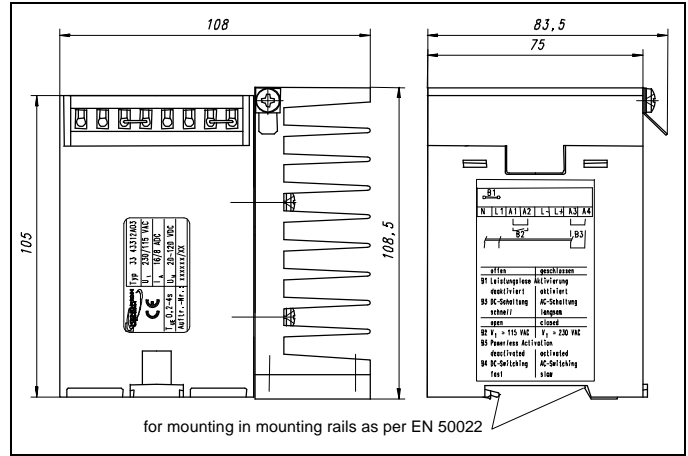

for mounting in mounting rails as per EN 50022

Factory settings

Type 33 433	Overexcitation time t_{oe} [s]	Holding voltage V [VDC]
	Nominal value	Nominal value
12A03	$2 \pm 0,2$	63 ± 3

Application hints

The technical data apply to rectifiers installed in switch cabinets with a minimum distance of 30 mm to adjacent units. In case the distance to other components is less than 30 mm, the power consumption must be reduced by 20%. The rectifier operates as bridge rectifier during the selected overexcitation time and subsequently reduces the output voltage to the selected holding voltage by phase shift control. It is crucial to ensure that the total power consumption does not exceed the rated power of the connected unit. The rectifier must only be used within the limits shown in diagram 1 in order to avoid

overloading. The maximum switching frequency can be determined on the basis of formula 1. The overexcitation time should be lower than 80% of the duty cycle. Ongoing DC-side switching when operating in overexcitation mode isn't allowed due to a possible damage of the protection circuit. The holding voltage adjustment should be done with connected load. **Attention!** To use the powerless switching feature a potential free relays contact is necessary because the terminals are internal connected with the AC input.

Ordering example Overexcitation rectifier

